

# AUTO TEST

## Khanacross Regulations

### I. DEFINITION - KHANACROSS

#### 1.1 Khanacross is defined by NCR 18A as:

a competition conducted on predominantly unsealed surfaces and involving a series of timed tests of various layouts. Khanacross is not, and may not include, a speed event. No straight section of the course may exceed 100 metres in length without a turn of at least 90°. Each test shall be designed to test the acceleration, braking and general manoeuvrability of the vehicle and the skill and judgement of the driver. The course for each test shall be marked by the appropriate use of arrows and/or direction markers. Only one car is allowed on each test at any one time. No passengers may be carried in any vehicle during competition.

#### 1.2 Course is defined as:

The description “course” shall apply to that individual path and combination of manoeuvres which a driver is required to complete in the prescribed manner.

### 2. THE COMPETITION

The object of the competition is for each driver to complete all the courses of the program in the prescribed manner, in the shortest possible time, without incurring penalties.

Khanacross events are regarded as one of the introductory levels in the spectrum of motor sport. They offer to clubs and Competitors the opportunity to conduct and take part in events conducted under the National Competition Rules of CAMS, in which the essential skills of car control and judgement may be practised under conditions which avoid the many hazards of public roads.

### 3. EVENT LAYOUT

#### 3.1 Courses must not exceed 1.5km in length and may not include any sealed section greater than 50 metres.

No straight section of the course may exceed 100 metres in length without a turn of 90° or more, otherwise cars must stop in a garage. The 90° turn must pass through an established area of 10m x 10m (refer diagram 3.1.1). The Competitor should not normally be required to reverse while competing, at the Clerk of the Course’s discretion. Markers shall clearly define the correct course to be taken.

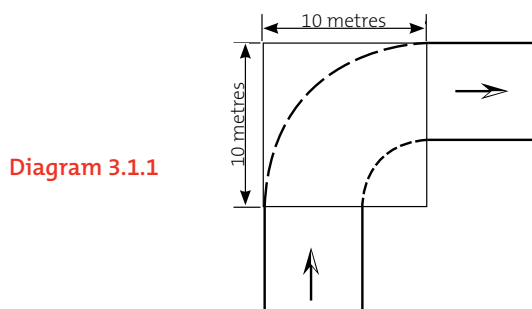

Diagram 3.1.1

#### 3.2 Enclosures for paddock and/or spectator cars must be at least 10 metres from the course, unless protected by a barrier sufficient to stop a competing car, in which case they must be at least five metres from the course.

#### 3.3 The course shall be denoted by suitable markers or arrows. These should be made and placed so that they are easily seen by Competitors, especially if the event is to be run at night. All arrows should be placed approximately 1.2 metres above the ground.

#### 3.4 Each course shall be used only once in each direction during an event.

#### 3.5 Bunting, if used, should not be affixed to course markers.

#### 3.6 Start/finish garages:

- (i) The Start/Finish garages may be the same garage or two separate garages. In either case the garages shall be four metres wide and 10 metres long. All starts will be standing starts and all finishes shall be within the finish garage. If required, course garages of 10 x 4 metres may be placed in the course and Competitors would be required to stop in each garage. A penalty, under 13.4(v) will be applied if the Competitor does not stop.
- (ii) All garages will have a minimum of eight flags.
- (iii) The finish line shall extend across the front of the finish garage of each course and shall extend four metres either side.



#### 4. PROGRAM

- 4.1 Not less than four courses must be completed for the event to be valid, except in the case of force majeure recognised by the Stewards of the Event.
- 4.2 Competition numbers shall be allocated by a method specified in the Supplementary Regulations. This may be by a ballot, in which case it should be conducted within each class.
- 4.3 The running order of the entire field may be rotated on an equitable system, based on classes, and advised in the Supplementary Regulations.

#### 5. VEHICLE REQUIREMENTS

- 5.1 All vehicles must comply with CAMS Group 4H and Schedule A of the NCR (refer “General Requirements for Cars and Drivers” in the CAMS Manual of Motor Sport).  
All vehicles defined as a special by Group 4H must be fitted with a roll over protection structure complying with Schedule J (refer “General Requirements for Cars and Drivers”).
- 5.2 All competing vehicles shall be scrutineered for safety and eligibility before the start of the event, including any convoy run. Particular attention will be paid to brakes, steering and tyres.
- 5.3 The Clerk of the Course shall rule on the acceptability of any vehicle to compete in the event and on the class in which it shall compete. Acceptable standards of presentation and condition must be met.
- 5.4 A driver whose vehicle has broken down may use a replacement vehicle, provided the consent of the Clerk of the Course has first been obtained. The replacement vehicle must be scrutineered, should preferably be in the same class as the original vehicle, and must be used for the remainder of the competition.
- 5.5 A fire extinguisher of at least 900g capacity, complying with Schedule H of the NCR (refer “General Requirements for Cars and Drivers”) must be fitted.

#### 6. DRIVERS

- 6.1 Drivers must hold a current and valid CAMS Level 2NS or higher licence. No driver shall be under the age of 14 years. Drivers between the ages of 14 and 16 must have previously competed in motorkhanas.
- 6.2 No driver shall enter a khanacross in more than one car.
- 6.3 For open vehicles and specials, neck to wrist to ankle clothing must be worn.
- 6.4 All drivers must wear suitable and appropriate footwear whilst competing. NCR 141(vii).
- 6.5 All drivers shall wear a safety helmet complying with a standard listed in Schedule D of the NCR (refer “General Requirements for Cars and Drivers”).
- 6.6 Goggles or a helmet with visor (to AS 1609-1981) must be worn in all open cars and in closed cars which have the windscreen removed.
- 6.7 At least a three-point seat belt, properly adjusted, must be worn while competing.
- 6.8 Any driver or official who consumes, or is visibly affected by alcohol or drugs during an event (NCR 145A), shall be excluded from the event and dealt with in accordance with the NCR.

#### 7. CLASSES

A	0 - 1300cc
B	1301cc - 1600cc
C	1601cc - 2000cc
D	Over 2000cc
E	4H Vehicles (Motorkhana Specials)
F	4-Wheel Drive Production Cars

Non-Production 4WD or 4WS vehicles are not permitted.

**Note:** This is a recommended class structure. Clubs may vary or expand this structure in accordance with approved Supplementary Regulations.

#### 8. PROCEDURE

- 8.1 **Convoy run:** So that each Competitor may be familiar with each course, a convoy run will be held before the start of competition on that course. This convoy run will be held before the start of competition on that course. This convoy run will be led by the Clerk of the Course or his nominee and will not exceed 20km/h. Competitors will follow the lead car. Only Competitors shall be allowed in the convoy, except as provided in 8.2(i).

**Note: It is each Competitor’s responsibility to participate in the convoy run. No re-runs will be granted to a Competitor who claims to have missed the convoy run.**

#### 8.2 Passengers:

- (i) No passengers may be carried in a vehicle while competing, except where 8.2(ii) applies. Any offending driver will be excluded from further participation in the event. Other Competitors may be carried as passengers during the convoy run, provided the vehicle provides proper accommodation for such passengers.
- (ii) Juniors may carry a passenger as an instructor in non-competitive activity only, subject to prior approval by



the Clerk of the Course Any instructor must be over 18 and hold a CAMS and civil driver's licence and comply with the safety requirements for apparel including helmet and use of seat belt. Instructors must sign the appropriate indemnity form.

- 8.3 A vehicle must complete the full distance of each course under its own power.
- 8.4 So long as a vehicle covers all the required course, even if this entails retracing of an incorrect path, the attempt shall be accepted as valid.
- 8.5 A speed limit of 10km/h shall apply in the area surrounding the competition courses and must be observed whilst proceeding between courses.

## 9. SUPPLEMENTARY REGULATIONS

Supplementary Regulations must be approved by CAMS and made available to all invited clubs and Competitors before the event. Course diagrams, with dimensions, must be supplied with the permit application.

## 10. START/FINISH

- 10.1 Vehicles must start and finish each course in a forward direction.
- 10.2 To start correctly, the vehicle must be stationary, wholly within the boundaries of the start garage and as close as practical to the front start garage before the commencement of the attempt at that course. Drivers will start in their own time, within 20 seconds of advice to start from the Start Garage Official.
- 10.3 To start or finish correctly, any point in the first half of the vehicle must precede all points in the rear half of the vehicle across the start or finish line.
- 10.4 A driver may request the assistance of an official when aligning his vehicle at the start line.
- 10.5 **To finish correctly, the following procedure must be observed:**
  - (i) The crossing of the finish line other than between the two front markers designating the finish garage, shall incur a penalty under Regulation 13.4(i) "Wrong Direction" unless at least one of those front markers is displaced. (Note Reg. 3.6(iii)).
  - (ii) After crossing the designated finish line, the vehicle must continue and stop completely within the boundaries of the finish garage.

This manoeuvre must be completed without reversing and within a period of approximately 10 seconds.

## II. METHOD OF SCORING

- 11.1 Results shall be decided on the total of elapsed times of the courses completed, plus any penalties. The winner/s shall be the driver/s having the lowest total, including penalties, at the completion of the event. In the case of equal scores, the tied Competitors shall be declared joint winners.
- 11.2 If the timing should fail to record a Competitor's time then the Competitor shall be offered a re-run.

## 12. METHOD OF TIMING

- 12.1 Times may be recorded to 0.01 second.
- 12.2 Timing shall commence when
  - (i) the leading point of the car crosses the designated start line or
  - (ii) when a driven wheel starts to rotate, and shall cease when the leading point of the car crosses the designated finish line.

The designated finish line shall be not more than one metre behind the front of the finish garage. The method of timing shall be specified in the supplementary regulations of the event.

## 13. PENALTIES

13.1 There are three basic penalties applicable in khanacross, viz:

(i)	Plus five (5) seconds
(ii)	Plus ten (10) seconds
(iii)	Slowest time plus five (5) seconds

A penalty of exclusion may also be imposed by the Stewards of the meeting for infringements as prescribed by the NCR.

- 13.2 The penalty of "plus five (5) or ten (10) seconds" means that the penalty amount shall be added to the time recorded by that driver on that course for each infringement.
- 13.3 The penalty of "slowest time plus five (5) seconds" shall be calculated by adding five seconds to the slowest time recorded by a driver who completed that course correctly, which then becomes the time for the penalised driver in lieu of that which that Competitor recorded.

When the *slowest time plus five (5) seconds* exceeds double the fastest time, the time to be applied shall be double the fastest time.

continued ...



**13.4** The application of these penalties shall be as follows:

(i)	Wrong Direction, any procedure other than that specified as the correct procedure for completing that course	Slowest time plus five (5) seconds
(ii)	Failure to complete a course or failure to attempt a course	Slowest time plus five (5) seconds
(iii)	Running out of order without the prior approval of the Clerk of the Course	Slowest time plus five (5) seconds
(iv)	Reversing after crossing the designated finish line	Slowest time plus five (5) seconds
(v)	Failing to stop at a mid course garage	Slowest time plus five (5) seconds
(vi)	Failing to stop completely at the finish of a course	Slowest time plus five (5) seconds
(vii)	Finishing a course with the car stopped but completely outside the garage	Slowest time plus five (5) seconds
(viii)	Striking a course marker or flag (including garage boundary marker or flag)	Plus five (5) seconds per flag/marker
(ix)	Finishing a course with part of the car outside the garage boundaries	Plus ten (10) seconds plus any markers or flags

#### **14. SPECTATORS**

**14.1** It is the responsibility of the Clerk of the Course to ensure that all spectators and Competitors are restricted to safe areas. To this objective, marshals should be appointed.

**14.2** Only appointed officials (persons authorised by the Clerk of the Course) and Competitors shall be allowed in the competition area.

**14.3** Animals must not be admitted to the competition or paddock areas.

#### **15. SAFETY EQUIPMENT**

It is recommended that a first aid kit and a fire extinguisher be provided at all events.

#### **16. OFFICIALS**

For Club and Multi-Club Khanacross, the Clerk of the Course is an Essential Official. In addition, an Assistant Clerk of the Course may be appointed to a Club or Multi-Club Khanacross. Either the Clerk of the Course or the Assistant Clerk of the Course must of necessity always be on duty and during such time the acting Clerk of the Course must be clearly and readily identifiable. The duties of the Secretary of the Meeting, Chief Timekeeper and Chief Scrutineer may be discharged by the Clerk of the Course or by another suitably qualified Official. While these duties are being discharged by such alternate Official, a Clerk of the Course and his Assistant (where an Assistant Clerk of the Course has been appointed), the Secretary of the Meeting, the Chief Timekeeper and the Chief Scrutineer may compete at the meeting. Any matter arising from the meeting which requires action by the Stewards shall be referred to a stewards' hearing which shall be organised by CAMS and which shall have the standing of a hearing by Stewards of the Meeting.

At a State or National Championship Khanacross, Essential Officials shall be appointed in full accord with NCR 162.